

# Single Edge Track - Undrilled

- Easy installation/available from stock
- Single edge design allows for flexible track pair spacing
- Patented mounting shoulder allows for accurate positioning of Vee ways
- Available from stock as induction hardened, polished and undrilled, AISI1045 carbon steel
- Induction hardened track remains soft below the mounting shoulder, allowing for drilling or other machining
- 420 stainless steel available on request
- Can be easily butt-joined for stroke lengths exceeding maximum single piece lengths (4 mtrs)

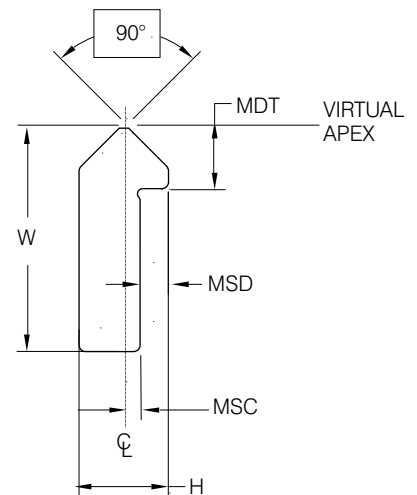

DualVee Track Part No.	Width W mm (inch)	Height H mm (inch)	Mounting Shoulder Location MDT mm (inch)	Mounting Shoulder to Centre Line MSC mm (inch)	Mounting Shoulder depth MSD mm (inch)	Weight Kg/m (lbs./ft)
T1	11.10 (0.437)	4.75 (0.187)	3.17 (0.125)	0.79 (0.031)	1.57 (0.062)	0.272 (0.183)
T2	15.87 (0.625)	6.35 (0.250)	4.75 (0.187)	0.79 (0.031)	2.39 (0.094)	0.510 (0.343)
T3	22.22 (0.875)	8.71 (0.343)	6.35 (0.250)	1.57 (0.062)	2.77 (0.109)	1.03 (0.690)
T4	26.97 (1.062)	11.10 (0.437)	7.92 (0.312)	2.36 (0.093)	3.17 (0.125)	1.64 (1.100)

Track available from stock to 4 metres cut to 500mm increments

### Ordering Example:

T1-1000 represents a 1 metre length of hardened, carbon steel, size 1 track  
 T1-1000-SS represents a 1 metre length of stainless steel size 1 track

### Notes:

1. All dimensions are in mm and (inches).
2. The overall length tolerance is  $\pm 1.6\text{mm} / \pm 1/16$  inch.
3. For non-standard track lengths or other non-standard options, contact TEA for quotation.
4. Maximum single piece track lengths: hardened = 6.096 mtr, unhardened = 6.7056 mtr.



# Guide Wheel Dimensions and Materials



Part Number	Dimensions <sup>3,11</sup> in inches					Material						
	Outside Diameter A	Bore Size B <sup>4,5</sup>	Width W <sup>6</sup>	Inside Vee Radius MDw Inside	Outside Vee Radius MDw Outside	Outer Race <sup>8</sup>	Inner Race <sup>8</sup>	Ball <sup>8</sup>	Retainer <sup>1</sup>	Shield <sup>1</sup>	Seal <sup>2</sup>	Grease <sup>7</sup>
W1X	0.771	0.1875	0.310	0.313	0.468	52100	52100	52100	Nylon 66	A591	NBR	Alvania 2
W2X	1.210	0.3750	0.438	0.500	0.719	52100	52100	52100	Nylon 66	A591	NBR	Alvania 2
W3X	1.803	0.4724	0.625	0.750	1.063	52100	52100	52100	Nylon 66	A591	NBR	Alvania 2
W4X	2.360	0.5906	0.750	1.000	1.375	52100	52100	52100	Nylon 66	A591	NBR	Alvania 2
W4XXL	2.968	0.8661	1.000	1.250	1.750	52100	52100	52100	Nylon 66	A591	NBR	Alvania 2
W1SSX	0.771	0.1875	0.310	0.313	0.468	440C	440C	440C	Nylon 66	304	NBR	Alvania 2
W2SSX	1.210	0.3750	0.438	0.500	0.719	440C	440C	440C	Nylon 66	304	NBR	Alvania 2
W3SSX	1.803	0.4724	0.625	0.750	1.063	440C	440C	440C	Nylon 66	304	NBR	Alvania 2
W4SSX	2.360	0.5906	0.750	1.000	1.375	440C	440C	440C	Nylon 66	304	NBR	Alvania 2
W4SSXL	2.968	0.8661	1.000	1.250	1.750	440C	440C	440C	Nylon 66	304	NBR	Alvania 2
W1SS227 <sup>9,10</sup>	0.771	0.1875	0.310	0.313	0.468	440C	440C	440C	304	304	None	Krytox227
W2SS227 <sup>9,10</sup>	1.210	0.3750	0.438	0.500	0.719	440C	440C	440C	304	304	None	Krytox227
W3SS227 <sup>9,10</sup>	1.803	0.4724	0.625	0.750	1.063	440C	440C	440C	304	304	None	Krytox227
W4SSCR <sup>10</sup>	2.360	0.5906	0.750	1.000	1.375	440C	440C	440C	304	304	None	Krytox227

**Notes:**

- "A591" shield material (JIS SECC) is cold rolled carbon steel with electrolytic zinc coating (classified by ASTM A591). "304" reflects 304 stainless steel.
- "NBR" seal material is nitrile butadiene rubber.
- All dimensions in inches unless otherwise indicated.
- Bore ID tolerance is +.0000, -.0003 inch, except W4XL.
- W4XL Bore ID tolerance is +.0000, -.0004 inch.
- Width tolerance is +.0000, -.0047 inch.
- Krytox GPL 227 is a DuPont product. Alvania # 2 is a Shell Oil product.
- "52100" reflects hardened AISI 52100 bearing steel (Rc 60-62); "440C" reflects hardened AISI 440C stainless steel (Rc 58-60).
- High Temperature Compatible - Heat stabilized components allow for operating temperatures to 500°F.
- Clean Room Compatible - All stainless steel components are internally lubricated with Krytox GPL 227.
- Guide wheels are manufactured to ABEC class 5 tolerances.
- Weights: W1 - 12g, W2 - 40g, W3 - 136g, W4 - 285g.

# Guide Wheels

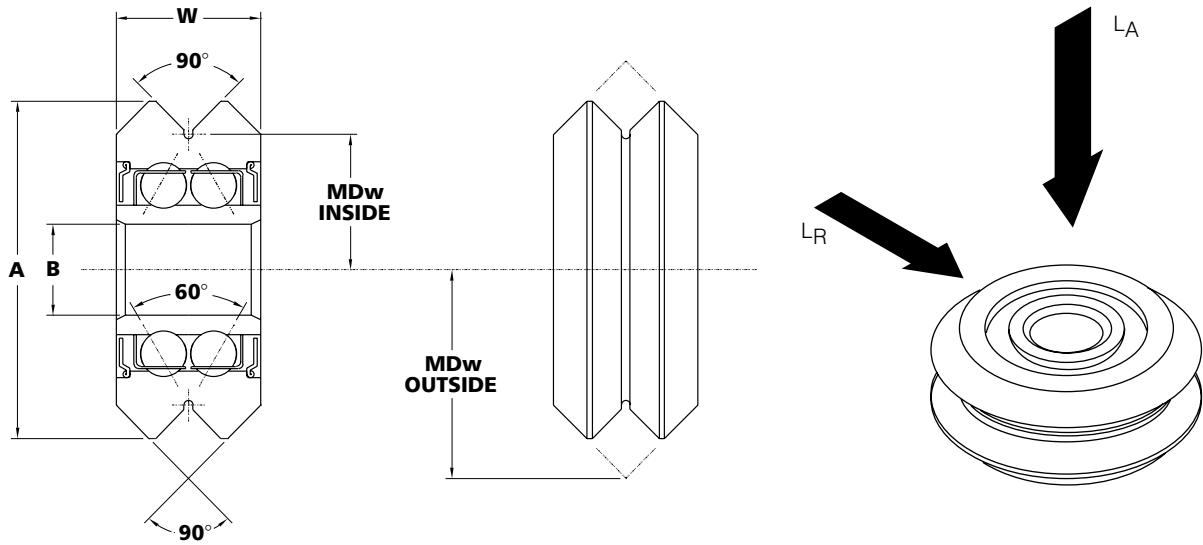

Part Number	Load Capacity (lbf)						Load Capacity (N)					
	Radial Working Load Capacity LRmax (lbf) <sup>2,3</sup>	Axial Working Load Capacity LAmax (lbf) <sup>2,3</sup>	BDLR Radial (lbf) <sup>1</sup>	BSLR Radial (lbf) <sup>1</sup>	BDLR Axial (lbf) <sup>1</sup>	BSLR Axial (lbf) <sup>1</sup>	Radial Working Load Capacity LRmax (N) <sup>2,3</sup>	Axial Working Load Capacity LAmax (N) <sup>2,3</sup>	BDLR Radial (N) <sup>1</sup>	BSLR Radial (N) <sup>1</sup>	BDLR Axial (N) <sup>1</sup>	BSLR Axial (N) <sup>1</sup>
<b>W1X</b>	134	57	490	250	245	234	595	252	2180	1110	1090	1040
<b>W2X</b>	322	140	1057	625	535	591	1431	625	4700	2780	2380	2630
<b>W3X</b>	691	382	2057	1135	1012	1079	3074	1701	9150	5050	4500	4800
<b>W4X</b>	1058	899	2878	1776	1428	1675	4704	4001	12800	7900	6350	7450
W4XXL	1702	1473	4631	3215	2338	3035	7571	6552	20600	14300	10400	13500
<b>W1SSX</b>	134	57	490	250	245	234	595	252	2180	1110	1090	1040
<b>W2SSX</b>	322	140	1057	625	535	591	1431	625	4700	2780	2380	2630
<b>W3SSX</b>	691	382	2057	1135	1012	1079	3074	1701	9150	5050	4500	4800
<b>W4SSX</b>	1058	899	2878	1776	1428	1675	4704	4001	12800	7900	6350	7450
W4SSXXL	1702	1473	4631	3215	2338	3035	7571	6552	20600	14300	10400	13500
W1SS227	111	47	407	207	202	196	494	208	1810	920	900	870
W2SS227	267	117	877	519	445	490	1188	520	3900	2310	1980	2180
W3SS227	574	314	1709	944	832	899	2554	1399	7600	4200	3700	4000
W4SSCR	876	746	2383	1475	1185	1389	3896	3320	10600	6560	5270	6180

**Bold** = usual stock item

Notes:

1. The BDLR (Basic Dynamic Load Rating) and BSLR (Basic Static Load Rating) are according to AFBMA STD 9-1990. These ratings are based on industry standard bearing calculations and are for comparison to other products as measured against the same standard. Maximum working load figures should be used for component sizing and selection.
2. Sizing and selection should be based on working load capacity ratings according to the sizing guidelines presented in the technical reference section (see load/life relationship).
3. Working load capacities reflect lubricated wheel/track interface.
4. See pages 229-232 for further discussion on load/life relationship.

# Bushings

- Rigidly affixes guide wheels to a mounting surface in a precise, orthogonal fashion
- Material options include 303 stainless steel (on request) or nickel plated carbon steel (stocked)
- Concentric and eccentric configurations allow for fit up adjustment
- Design calls for a fastener to pass through the bushing and the guide wheel, locking the elements into place against the mounting surface

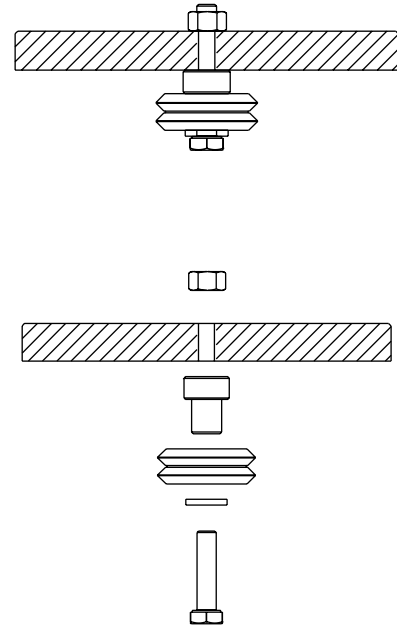

# Metric

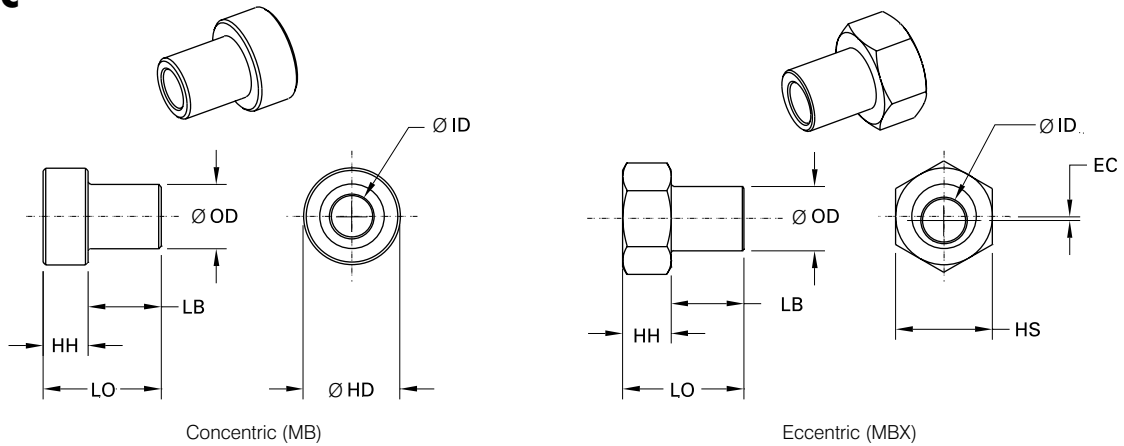

DualVee Size	Part Number	Recommended Fastener Size	Hex Size	Offset	Head Height	Length Body	Length Overall	Outside Diameter	Inside Diameter	Head Diameter
			HS	EC	HH <sup>7</sup>	LB	LO	OD <sup>3</sup>	ID <sup>8</sup>	HD
1	<b>MB1</b>	<b>M4</b>	-	-	6.22	7.6	13.8	4.76	3.96	11.2
	<b>MBX1</b>	<b>M4</b>	12	0.25	6.22	7.6	13.8	4.76	3.96	-
2	<b>MB2</b>	<b>M6</b>	-	-	6.65	10.8	17.4	9.52	6.00	14.2
	<b>MBX2</b>	<b>M6</b>	14	0.61	6.65	10.8	17.4	9.52	6.00	-
3	<b>MB3</b>	<b>M8</b>	-	-	9.47	15.6	25.1	11.99	8.00	19.1
	<b>MBX3</b>	<b>M8</b>	19	1.07	9.47	15.6	25.1	11.99	8.00	-
4	<b>MB4</b>	<b>M10</b>	-	-	11.10	18.8	29.9	15.00	10.00	22.4
	<b>MBX4</b>	<b>M10</b>	22	1.52	11.10	18.8	29.9	15.00	10.00	-
4XL *	<b>MB4XL</b>	<b>M14</b>	-	-	14.35	25.1	39.5	21.97	14.00	31.8
	<b>MBX4XL</b>	<b>M14</b>	30	1.52	14.35	25.1	39.5	21.97	14.00	-

**Bold** = usual stock item

\* Available on request

Notes:

1. All dimensions are in mm.
2. Standard materials are electroless nickel plated carbon steel or 303 stainless steel. Add "-SS" to the end of the part number for stainless steel.
3. The bushing's outside diameter is designed to fit the corresponding size DualVee® guide wheel. Outside diameter (OD) tolerance is +0.00mm, -0.03mm.
4. Part # MBX\_ indicates eccentric (adjustable) bushing; rotation of eccentric allows fit up adjustment between track and guide wheels.
5. All mounting information within this catalogue assumes a central position of the eccentric bushing, thus allowing wheel position adjustment from "+EC" to "-EC".
6. Part # MB\_ indicates concentric (stationary) bushing; Since concentrically mounted wheels have a fixed position, these bushings set the alignment of the carriage assembly to the rail. Concentrically mounted wheels should be configured to carry the majority of the load whenever possible.
7. Head height (HH) tolerance is ±0.03mm.
8. Inside diameter (ID) tolerance is +0.05mm, -0.00mm.